



Edition : 1.0  
Date: (03/26)

## Instruction Manual

Suits SC-1800 & BSC-900 Storage Cupboards

# 100mm Deep - NT40/BT40 DRAWER KIT

## SCD-40H

Order Code: (T762E)

## BEFORE ASSEMBLING

Please read this instruction manual before assembly.



### CAUTION

Before assembly please pay attention to the following points in priority;

**Confirmation of components:** Before assembling, please confirm all parts arrived and are in good order.

**Site for assembly:** Please assemble it on the soft floor such as smooth carpet and flannel blanket. When you assemble on wooden floor, please put thin towels on the floor.

**Points for attention when assembling:** Please wear gloves to ensure that it can be assembled safely, and use two persons to help in the assembly process.

**Matters needing attention for operation:**

- Do not use for in proper use.
- Do not use it on inclined surface or uneven places.
- Do not use it when screws and fasteners are loosened.

## TOOLS REQUIRED FOR ASSEMBLY

- Phillips Head Screwdriver

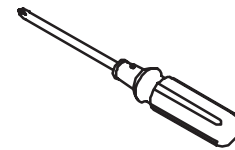

**SUITS - INDUSTRIAL STORAGE CUPBOARDS**



**BSC-900**  
(T774)



**SC-1800**  
(T762)

## PARTS LIST - DRAWERS

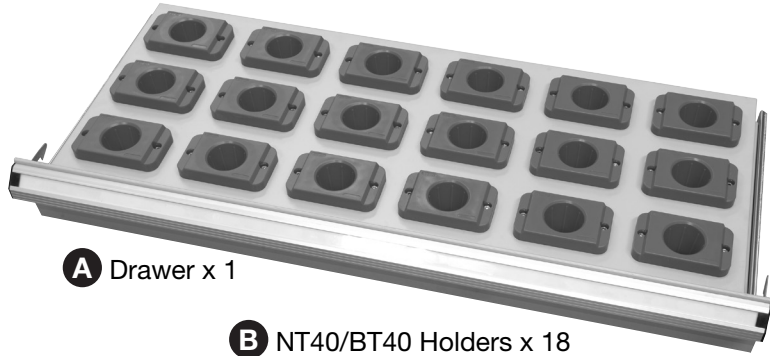

**A** Drawer x 1

**B** NT40/BT40 Holders x 18

Part No.	Description	Qty
A	100mm Drawer	1
B	NT40/BT40 Holders	18
E	Screw	8
F	Lock Bracket	2
G	Drawer Slide Set	1



**E** Screw x 8

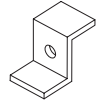

**F** Lock Bracket x 2

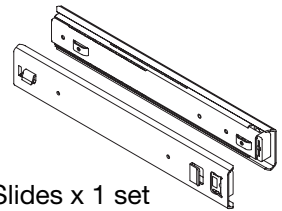

**G** Drawer Slides x 1 set

## ASSEMBLING THE DRAWER

**STEP 1:** Insert NT40/BT40 Holders (B) into the drawer (A) as shown below.

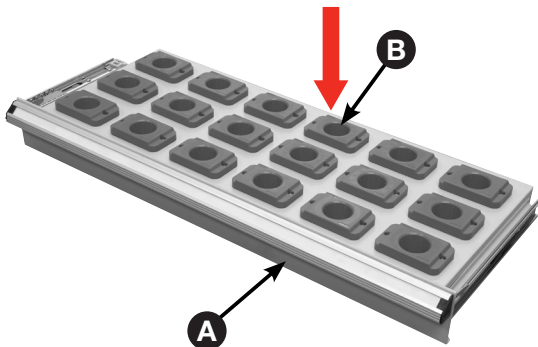

**STEP 2:** Slide apart the drawer slide sets (G) by pushing up or down on the plastic release levers (G2). Now attach brackets (G2) into slots on both sides of drawers (A) and fix in place with 2 screws (E) on each bracket (G2) as shown below.

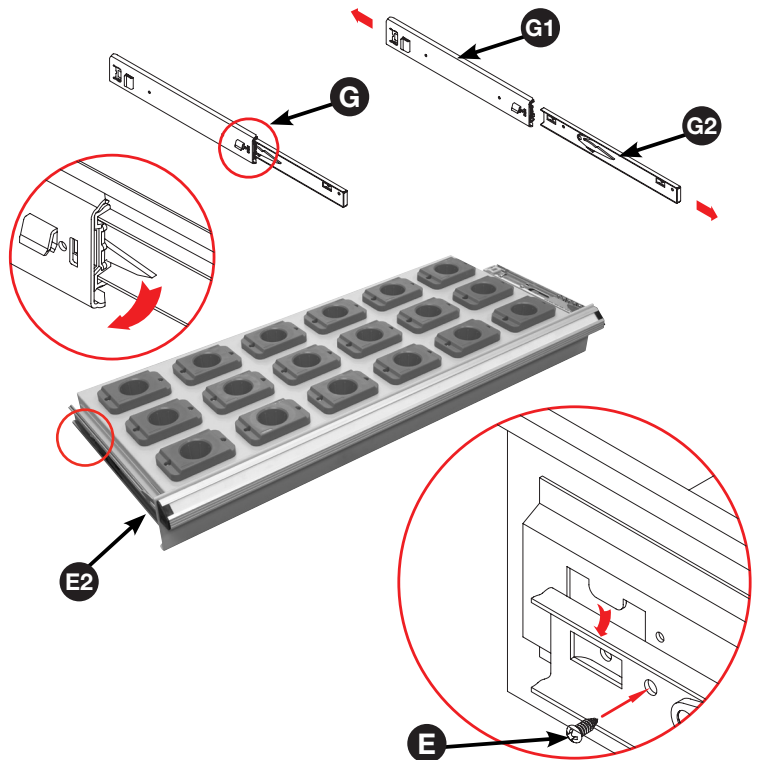

## ASSEMBLING THE DRAWER Cont...

**STEP 3:** Insert the drawer slide brackets (G1) into slots on at desired height on both sides of cabinet body then fix in place with 1 x screw (E) per bracket (G1). Insert the lock bracket (F) into the slot above the drawer slide bracket (G1) and fix with screw (E). Height of bracket (F) is adjusted with the size of drawers.

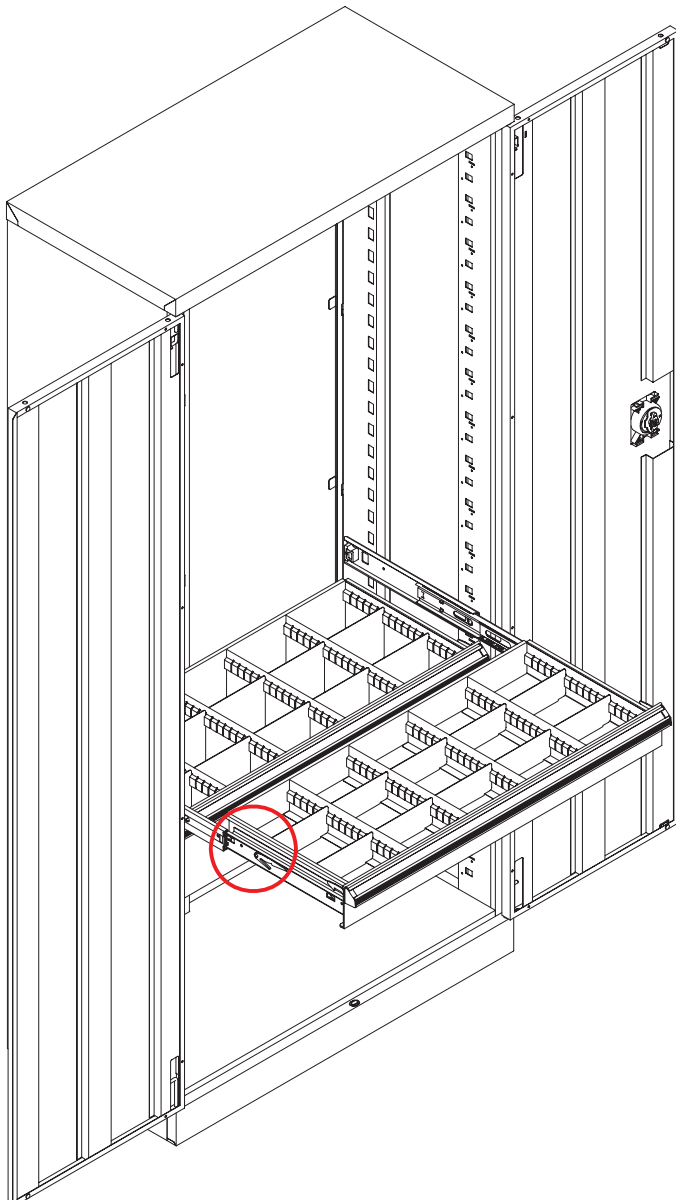
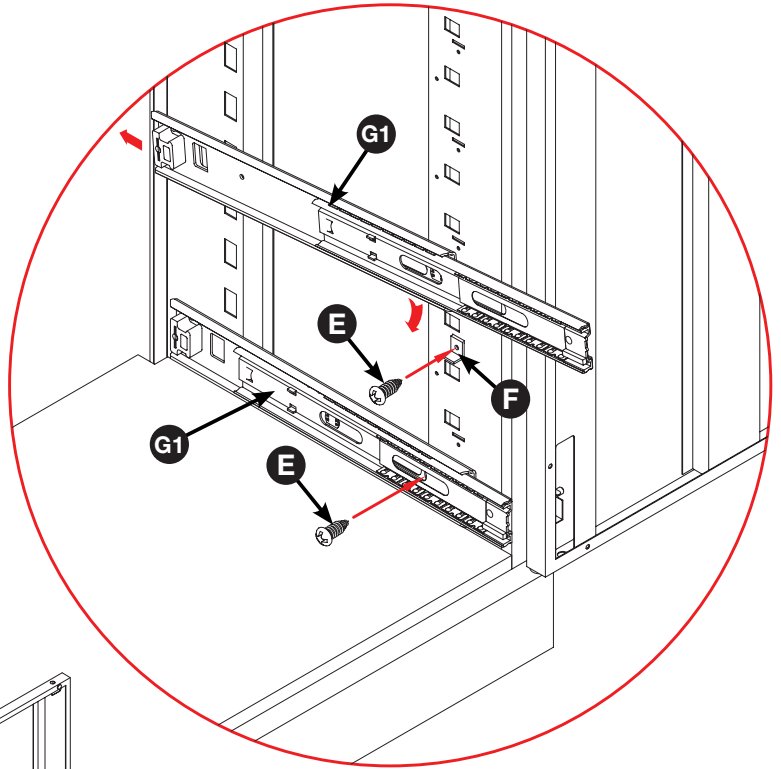

**STEP 4:** Extend the drawer slides (G2). Insert the brackets on each side of the drawer into the slots on the slides (G1), being careful that they are properly positioned. Once properly inserted, completely close the drawer to set the slides in their proper positions.

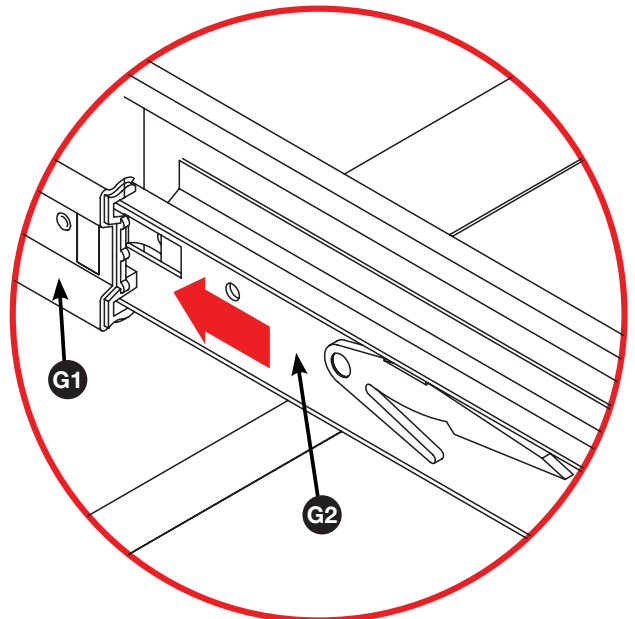



### **ENVIRONMENT PROTECTION**

Recycle unwanted materials instead of disposing of them as waste. All tools, accessories and packaging should be sorted, taken to a recycling centre and disposed of in a manner which is compatible with the environment. When the product becomes completely unserviceable and requires disposal, drain any fluids (if applicable) into approved containers and dispose of the product and fluids according to local regulations.

Imported by

---

**HARE & FORBES**  
**MACHINERYHOUSE**

**Australian Distributor**

Hare & Forbes  
Machineryhouse  
Sydney - Melbourne  
Adelaide - Brisbane - Perth

Ph: 1300 202 200  
[www.machineryhouse.com.au](http://www.machineryhouse.com.au)

**MACHINERYHOUSE**

**New Zealand Distributor**

Machineryhouse  
Auckland  
Christchurch

Ph: 0800 142 326  
[www.machineryhouse.co.nz](http://www.machineryhouse.co.nz)